

MDA Series

FEATURES

- High current, low DCR, high efficiency.
- Very low acoustic noise and very low leakage flux noise.
- AEC-Q200 qualified
- 100% Lead(Pb)-Free and RoHS compliant.
- Operating temperature: -55 to +150 °C (including self-temperature rise)
- Quantity: 3000PCS

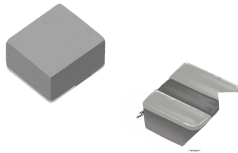

APPLICATION

- Headlamps, tail lamps and interior lighting
- HVAC
- Doors, window lift and seat control
- Audio subsystem
- Digital instrument cluster
- In-Vehicle Infotainment and navigation

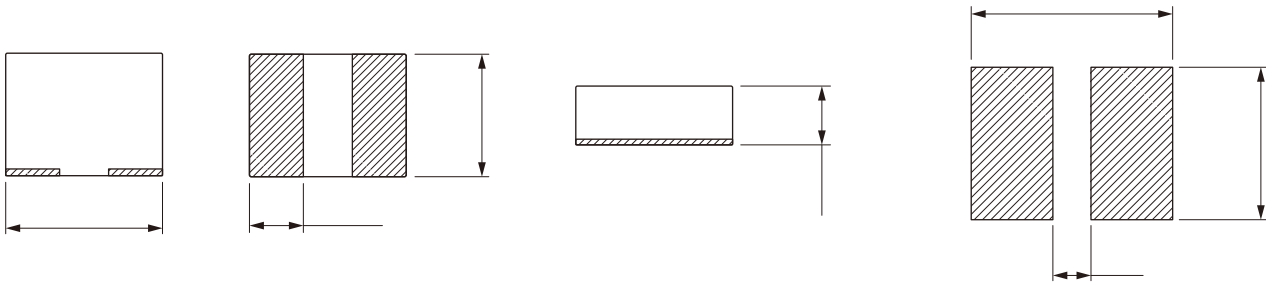

Part No	Inductance @ 1MHz/1V	Tolerance	Temperature Rise Current Typ.	Temperature Rise Current Max.	Current Typ.	Current Max.	DC Resistance Typ.	DC Resistance Max.
MDA252010-R33M	0.33	±20%	6.6	6.2	7.6	7.2	13	17
MDA252010-R68M	0.68	±20%	5.6	5.0	5.9	5.5	23	27
MDA252010-1R0M	1.00	±20%	4.5	4.1	5.3	4.8	24	28
MDA252010-2R2M	2.20	±20%	2.9	2.6	3.4	3.0	57	66
MDA252010-3R3M	3.30	±20%	2.5	2.2	2.8	2.5	86	100
MDA252010-4R7M	4.70	±20%	2.0	1.6	2.6	2.0	180	216
MDA252010-100M	10.0	±20%	1.2	1.1	1.6	1.4	490	520



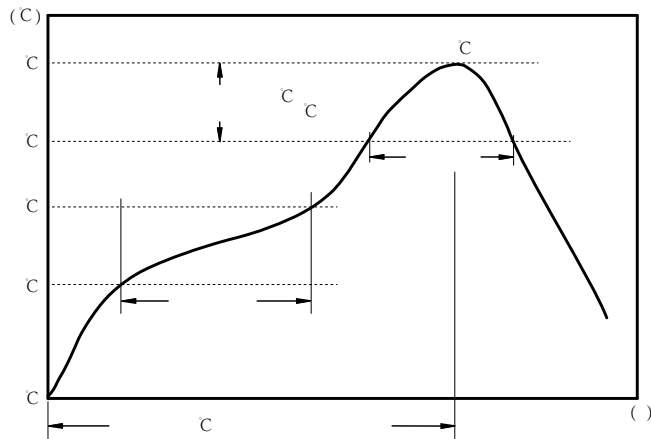

C
C
C

:

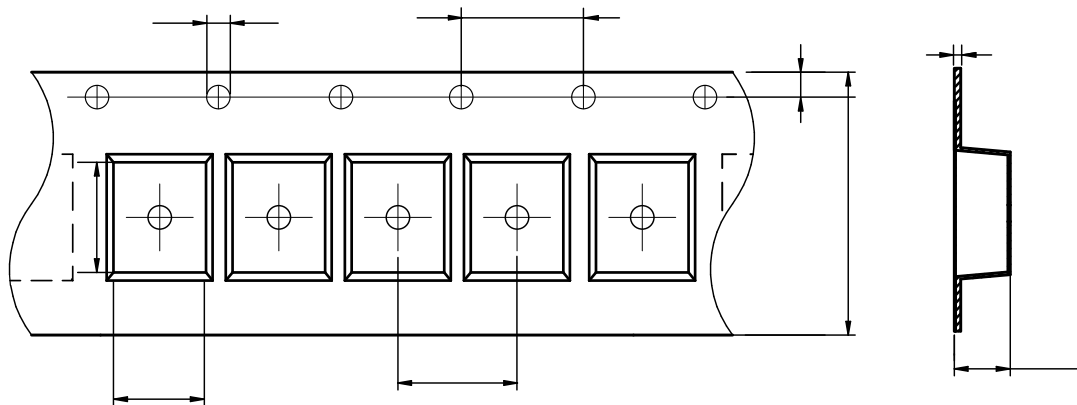

MDA252010	2.4± 0.1	2.9± 0.1	1.5± 0.1	4.0± 0.1	4.0± 0.1	8.0± 0.3	1.2± 0.1	1.75± 0.1	0.25± 0.05
-----------	----------	----------	----------	----------	----------	----------	----------	-----------	------------

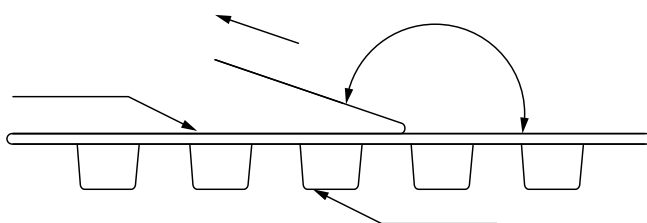

The peel force of top cover tape shall be between 0.1 to 0.98 N

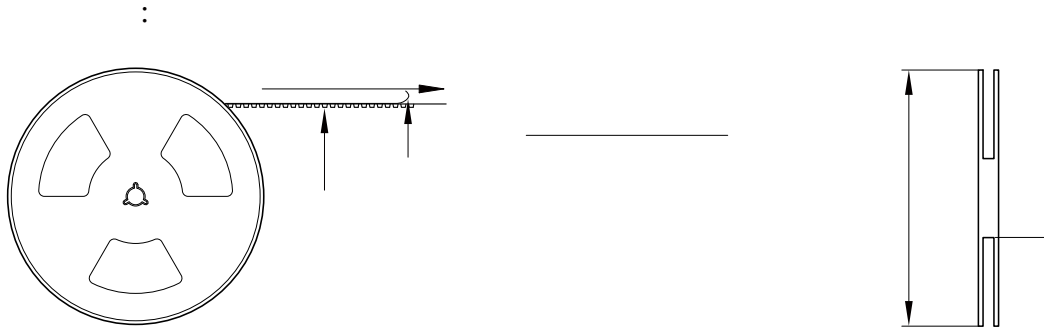

:

-
-
-
-
-
-
-
-
-