

MDSA Series

SMD Low Profile High Current Molded Inductor

Size 5030



FEATURES

-
-
-
-
-
-
-
-
-
-

APPLICATION

-
-
-

Dimensions: [mm]

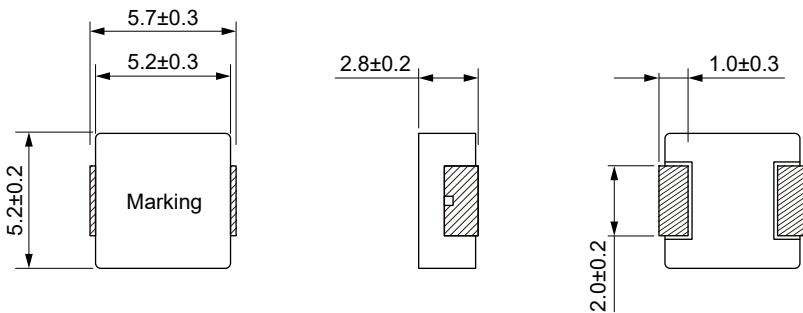

Land Pattern: [mm]

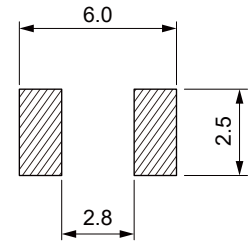

Electrical Properties:

Saturation Current will cause L to drop approximately 30%

Temperature Rise Current: The actual value of DC current when the temperature rise is $\Delta T=40^{\circ}\text{C}$

Typical Electrical Characteristics:

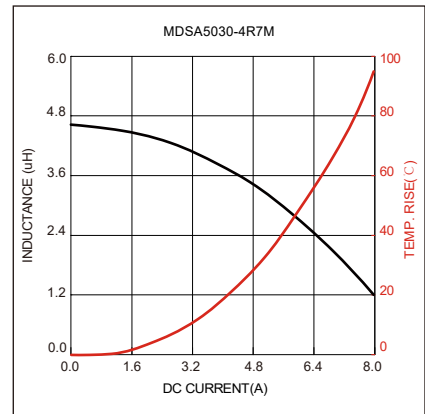
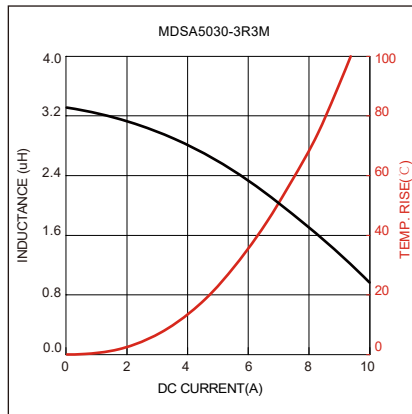
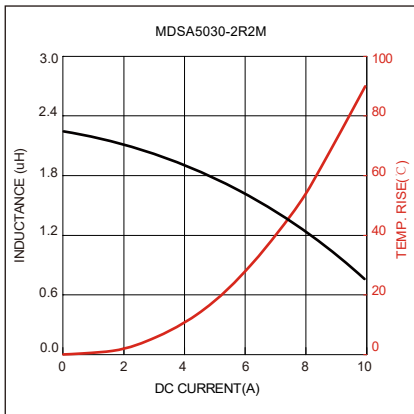
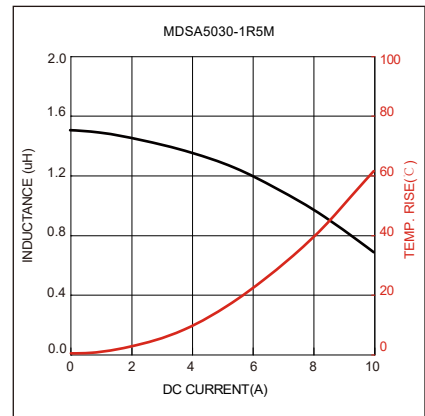
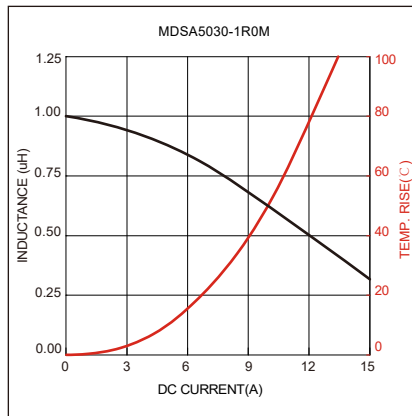
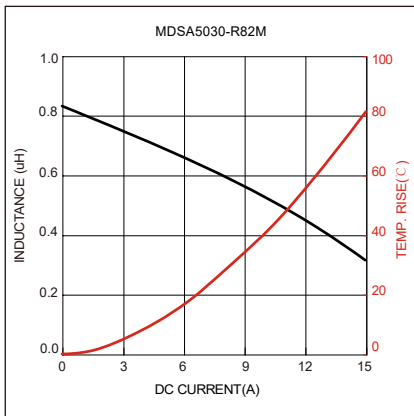
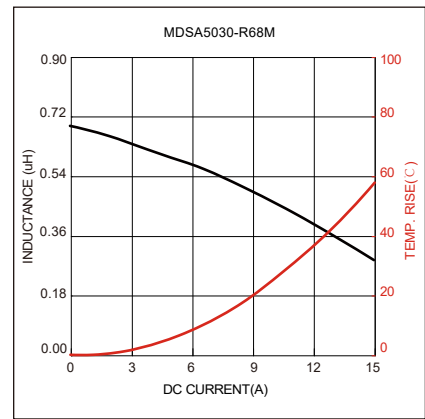
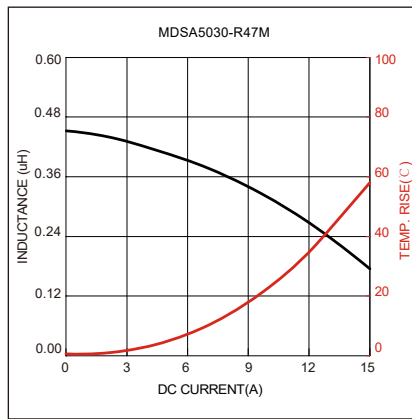
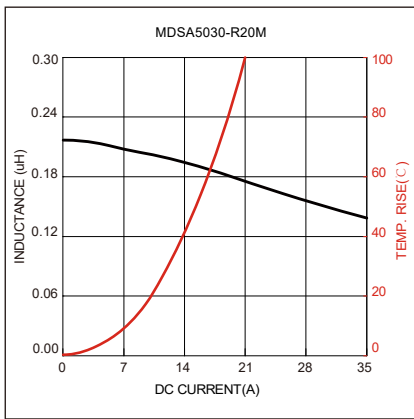

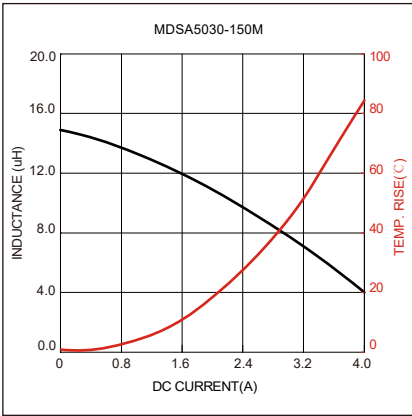
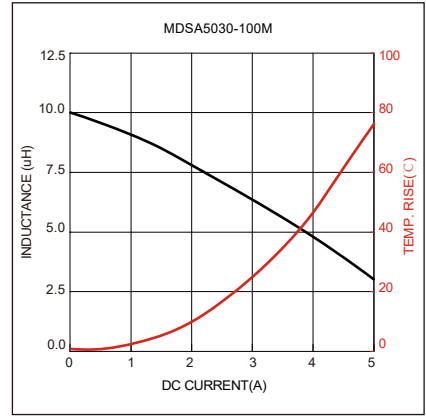
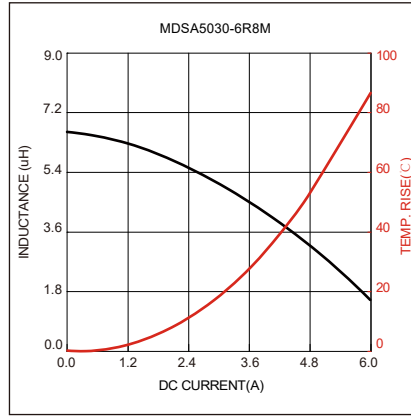
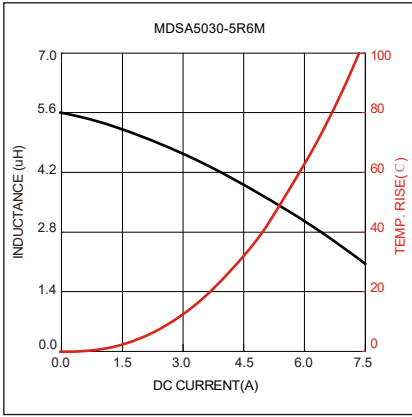

Soldering Reflow:

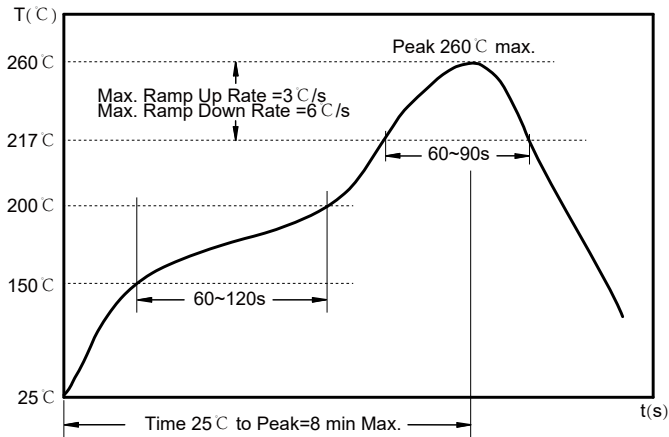

Preheat condition: 150 ~200°C / 60~120 sec.

Allowed time above 217°C : 60~90 sec.

Max temperature: 260°C .

Max time at max temperature: 10 sec.

Allowed Reflow time: 2x max.

Packaging Information:

Tape Dimension :

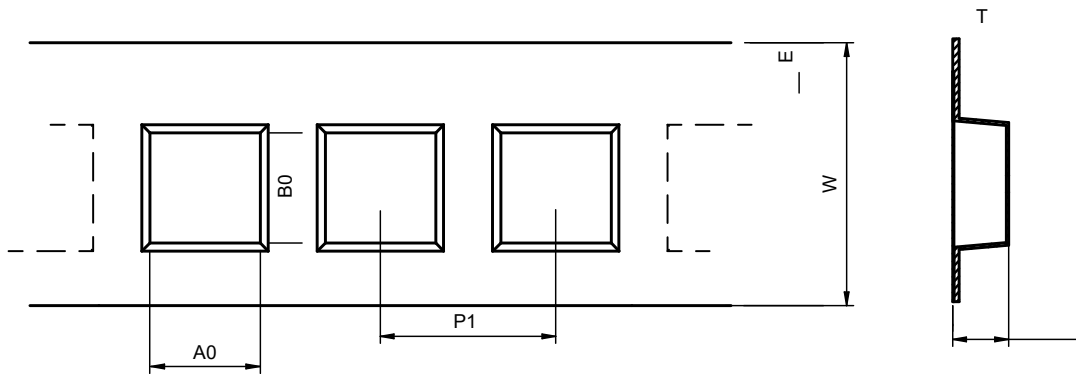

Series	A0 (mm)	B0 (mm)	D (mm)	P0 (mm)	P1 (mm)	W (mm)	K0 (mm)	E (mm)	T (mm)
MDSA5030	5.5±0.1	5.9±0.1	1.5±0.1	4.0±0.1	8.0±0.1	12.0±0.3	3.3±0.1	1.75±0.1	0.35±0.05

Peel force of top cover tape:

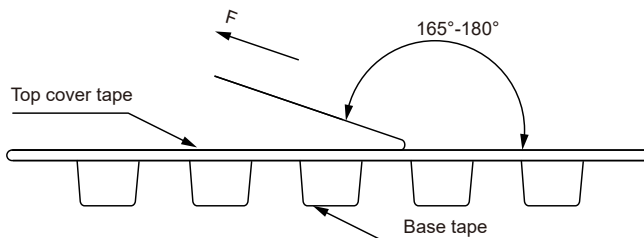

The peel force of top cover tape shall be between 0.1 to 1.3 N

Product Marking:

Marking	K+Printing (Inductance)
---------	-------------------------



Reel Dimension: [mm]



Packaging Quantity: